

01/2013

blive®



mesa / table

MOD 01



blive®

MOD 01
ref. 500028

design by HB

modelo registado / diseño registrado
modèle enregistré / registered design

Rua dos Poços nº 245 - Lameira
2425 - 774 Ortigosa, Leiria

tel (+351) 244 613 555
fax (+351) 244 613 556

geral@blive.pt
www.blive.pt

make your space.



5 600435 000283

ref. 500028

Material / Matériel
betão reforçado com fibras
hormigón reforzado con fibras
béton renforcé de fibres
fiber reinforced concrete

Peso / Poids / Weight
270 kg

Dim. paleta / Tam. paleta
Taille de la palette / Pallet size
75 x 80 cm

DIMENSÕES / TAMAÑO / MESURE / SIZE

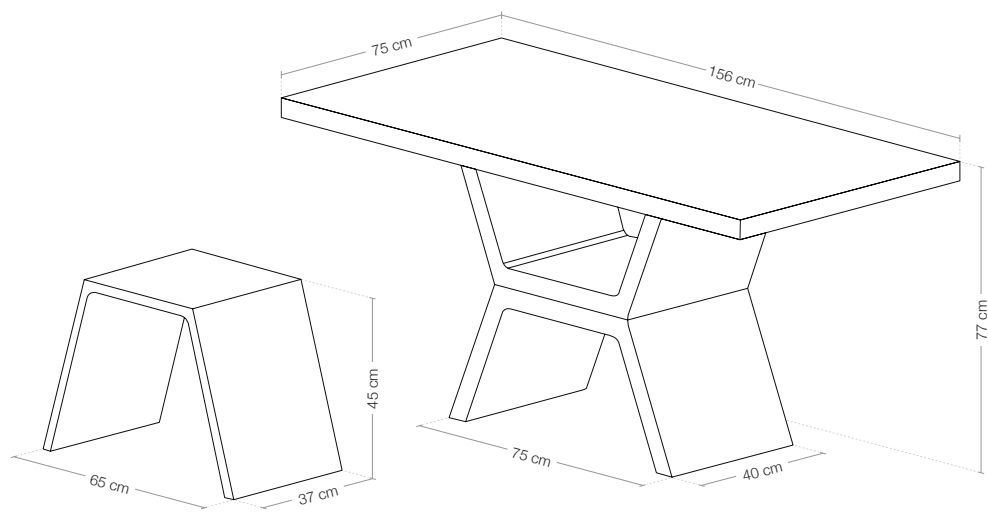

**INSTRUÇÕES DE MONTAGEM / INSTRUCCIONES DE MONTAJE
INSTRUCTIONS DE MONTAGE / ASSEMBLY INSTRUCTIONS**

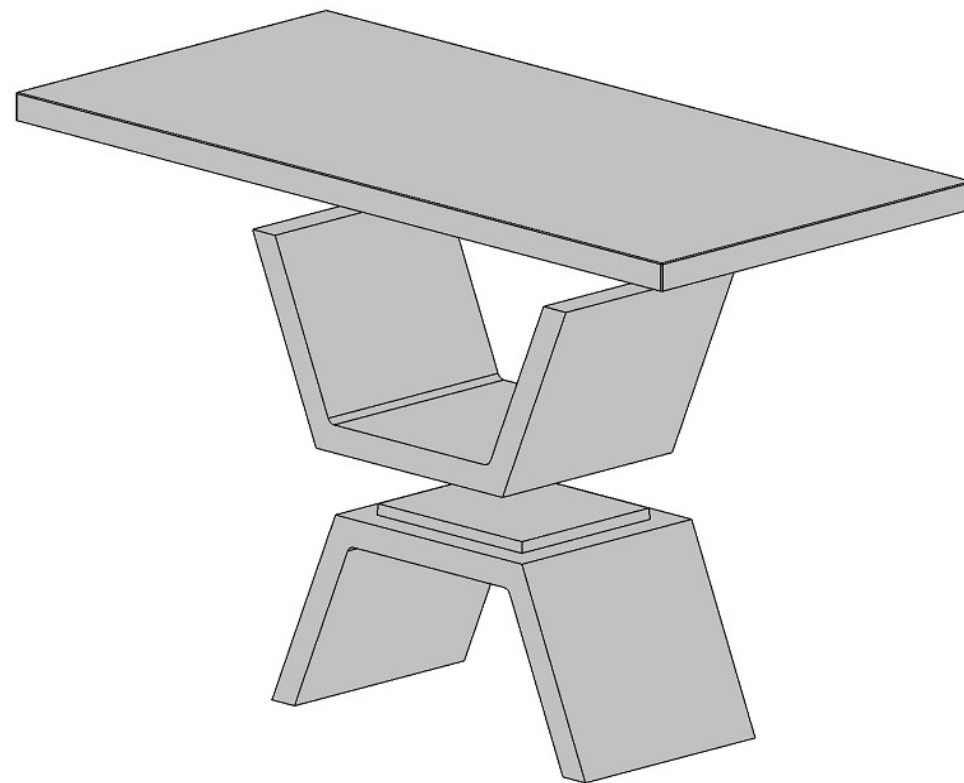

**ESTA EMBALAGEM CONTÉM / ESTE PAQUETE CONTIENE
L' EMBALLAGE CONTIENT / THIS PACKAGE CONTAINS**

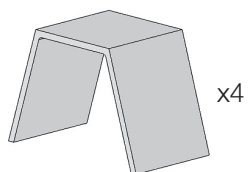
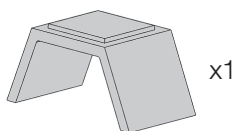
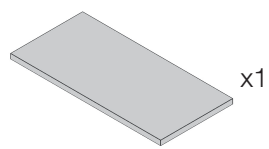
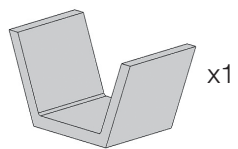

Atenção / Atención / Attention

